

Wood burning sauna heaters



Installation and user's manual

Thank you for choosing quality products from Saunatec

We think that our products will live up to your expectations and give you many hours of enjoyment in your sauna. We want you, your family and friends to have many comfortable sauna baths and at the same time find new ways to enjoy the sauna bathing.

Saunatec is the world-leading producers of products for saunas and steam saunas. We develop, produce and market products for saunas and steam saunas in the world. Saunatec has the largest factories of sauna products in the world (Finland, Germany and the USA) and a well-developed network of retailers, both nationally and internationally. Our product range consists of sauna and steam rooms, electric and wood heaters, control panels and sauna accessories.



Pentti Piisku, President, Saunatec Group Ltd

Index

Preparing the heater for use	4
Minimum safety distances	4
Wall protection and choices of material	6
Installation	7
Installation of heaters with front water tanks	8
Ventilation in a wood-burning sauna	8
Sauna rocks	8
Heating up	9
Water quality	9
Mounted water tank	9
Changing the direction of door opening	10
Heater care and maintenance	10
Troubleshooting	11

Preparing the heater for use

Read the instructions carefully before the first use! The heater is painted with heat-resistant paint and due to its chemical properties it may evaporate burning odours from its surface when heated for the first times. Therefore we recommend the first heating up to be done outdoors or in a well-ventilated sauna room. The first pre-heating must be done without stones. If the sauna stove is heated up outdoors it should be done with a 2 metre connecting pipe installed in order to get a good draught. In preheating the continuous heating with 3-5 loads of wood should be enough to remove the anti-corrosion substances from the heater.

One of the paint properties is that it reaches its final state only during the first heating times. Thus rubbing and wiping of the painted surfaces should be avoided before the first use. Handle the heater with care. The heater is likely to release paint odour for some time as any other painted materials.

Adjustable feet

The heater can be equipped with optional adjustable feet (shown here). Adjustable feet facilitate the installation of the heater on an inclined floor.

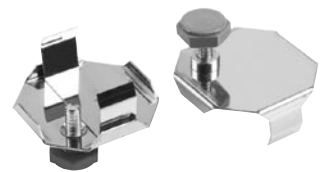

Installation point

Make sure there is enough space for installation and observe the safety distances. Heating up requires 1 m x 1 m around the heater. Place the heater far enough from combustible materials and protect the floor if the floor is tiled. See that there is space in the niche for air circulation (minimum of 100 mm).

Remember that the sauna rocks decay over time causing fine-grained rock material to fall to the floor with the steam water. The heat generated by the furnace and temperature changes may also cause small metal flakes to fall to the floor which is a normal property of metal.

Due to the above-mentioned facts it is a good idea to avoid using light-coloured materials near the heater. Always check the heat resistance of the tiles with the supplier.

Keep the floor under the heater clean.

Minimum safety distances

Minimum safety distances between the heater and combustible materials:

from the sides and back of the heater:	500 mm
from the front of the heater:	1000 mm
from the top of the heater to the ceiling: min.	1200 mm
from the heater to the floor (see Floor protection):	min. 50 mm

Statutory minimum safety distances to combustible materials can be reduced by half with single-layer and by 75% with double-layer light protection.

Side walls

Wood-burning sauna heaters are classified as burning surface fireplaces. The surface temperature of the heater will not rise above 350 °, and the following minimum safety distances should be observed. Combustible structural parts, such as wood walls, benches, etc.

1. Minimum safety distance from the vertical surfaces of the heater to unprotected wood structures: 500 mm. (Figure 1).

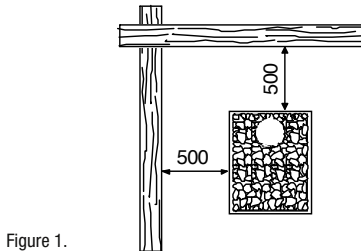

Figure 1.

2. The minimum safety distance mentioned in item 1 can, however, be reduced to no less than 250 mm when using "single-layer" protection. This type of light protection can be made of minimum of 7 mm thick non-combustible, fibre-reinforced concrete sheets or minimum of 1 mm thick metal sheet tightly mounted to the wall.

A minimum of 30 mm air gap must be left between the wood surface being protected and the protective sheet using, for example, duct bushings as spacers. (Figure 2).

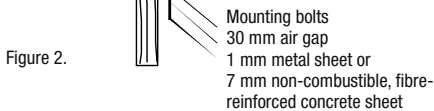

Figure 2.

3. The minimum safety distance shown in picture 1 can be further reduced to minimum of 125 mm when using double-layer protection.

Double-layer protection can be made two sheets mentioned in item 2 leaving a minimum of 30 mm air gap between the wall and sheet. (Figure 3).

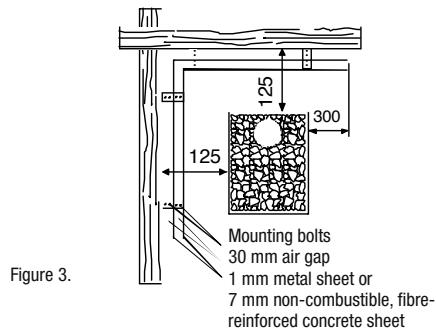

Figure 3.

4. If the wall is made of masonry, a 50 mm air gap between the vertical surfaces of the heater and the walls will be sufficient. (Figure 4).

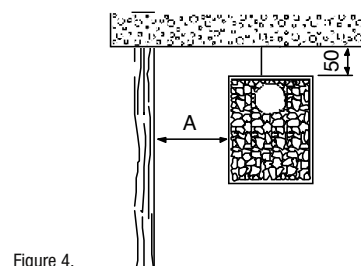

Figure 4.

Measurement A is for wood surfaces depending on the type of protection used.

- Without protection: 500 mm
- With single-layer protection: 250 mm
- With double-layer protection: 125 mm

5. A 55 mm masonry, which is open-ended and at least 30 mm from the surface being protected, is equivalent to single-layer protection.

Correspondingly, 110 mm masonry, which stands apart from the surface being protected, equals double-layer protection. (Figure 5).

Ceiling protection:

When the distance between the top of the heater and the ceiling is at least 1200 mm, no additional protection is necessary. If the distance is less than 1200 mm, applicable fire safety regulations must be observed. The edges of the ceiling protection must extend beyond the outer surfaces of the heater. (Figure 6).

Fireplace base

The fireplace must be mounted on a fixed base. The base must be able to withstand the weight of the heater and prevent the excessive rise in temperature of structural parts attached to it. When mounting a heater onto a wood floor, a minimum of 50 mm thick concrete slab or minimum of 7 mm thick fibre-reinforced concrete sheet covered by sheet metal must be used as a base. (Figure 7).

Floor protection in front of the heater:

The minimum safety distances listed in items 1-5 do not apply to combustible floor materials in front of the heater. The floor must be protected with a metal sheet which is tightly fastened to the floor and heater. This protection must extend at least 100 mm beyond the outer edges on both sides of the heater door and 400 mm out from the door. (Figure 7).

Note! There must be no electrical devices or wires within the minimum safety distance area surrounding the heater. For more detailed information on fire safety regulations consult your local fire authority.

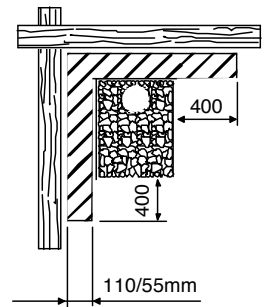

Figure 5.

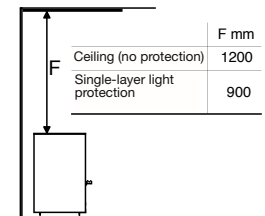

Figure 6.

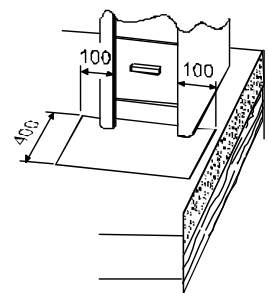

Figure 7.

Wall protection and choices of materials

If the wooden walls surrounding the heater are closer than the required minimum safety distance recommends and the walls are made of a combustible material (panels, boards, logs, etc) the wall surfaces must be protected.

A 55 mm masonry equals single-layer protection, and 110 mm masonry equals double-layer protection. The masonry must be open-ended and at least 30 mm from the surface being protected, extending 600 mm above the top of the heater and have a 500 mm minimum safety distance on each side.

Wood materials used in the sauna room, such as panels, will darken over time. This darkening is caused by temperature changes in the sauna. If the wall panels have been treated, the wall surfaces above the heater will begin to darken very quickly, depending on the treatment used. Darkening is due to the fact that the treatment has a weaker resistance to heat than untreated wood. This has been proved in material tests.

Fine-grained stone particles rising from crumbling sauna rocks with air currents may darken the wall surfaces around the heater. If the heater installation instructions are followed, the heater will not heat up combustible materials used in the sauna room to a dangerous level. The maximum allowed temperature for wall and ceiling surfaces is +140 °C. **Note! Glass and stone surfaces!**

Heater installation

In all our heater models there is a port for the connecting flue duct on top of and behind the heater. Close the unused port with the cap provided. With the heater there is also a 200 mm connecting flue duct, which can be used for rear-mounted flue ducts. Do not push the connecting flue duct too far into the chimney – this will block air flow. The gap between the masonry chimney and connecting flue duct must be insulated with, for example, mineral wool.

During installation ensure that the heater is fastened securely on its base, and that all the minimum safety distances listed in this manual are correct.

Connecting the heater to a masonry chimney

There are two ways to connect the connecting flue duct to the chimney. If the connecting flue duct is run from the top of the heater, the port in the back of the heater must be closed tightly with the cap provided (remove the cap on the top port).

The masonry connector is bricked into a hole made in the chimney at the correct height for connection to the flue duct port. The flue duct is connected to the heater, which is removed when the flue duct is inserted into the masonry connector. The optional flue duct feed-through collar is used to give a finishing touch over the masonry work around the flue duct. The feed-through collar is made of noble metal.

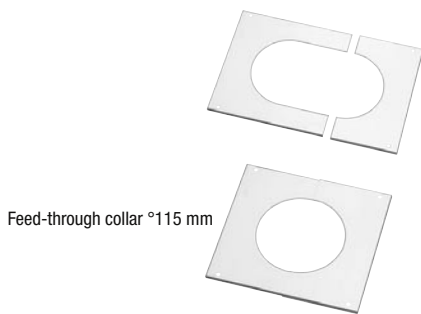

Feed-through collar \varnothing 115 mm



Masonry connector



Connecting flue duct 90°



Connecting flue duct 60°



Connecting flue duct 330-1000 mm

HELO and VIKI heaters

Model R	Flue port height to port center				
	from behind	on top w/ 60° connecting flue duct	90° connecting flue duct	upper tank + 60° connecting flue duct	duct-mounted tank + 90° connecting duct
Heat-retaining, ever ready HELO UKKOTONTTU	780	-	-	-	-
Soapstone heater HIIDENKIVI	590	1010	840	1630	1470
Continuous heating HELO 12	550	970	800	1590	1430
HELO 16 DX	600	1020	850	1640	1480
HELO 20 SL	600	1020	850	1640	1480
HELO 20 BLACKLINE	600	1020	850	1640	1480
HELO 22 DX	600	1020	850	1640	1480
HELO 28 DX	650	1070	900	1690	1530
HELO 40	930	1380	1200	-	-
Heaters w/ water tank HELO 18 ES BLACKLINE	650	1070	900	-	-
HELO 22 ES DX	650	1070	900	-	-
HELO 28 ES DX	650	1070	900	-	-
Cauldron HELO PATA DX Connected from the top or rear	650	1080	920	-	-

Note! These are measurements without adjustable feet

Installation of heaters with front water tanks

Permanently mounted to the front of the heater, the 24-litre hot water tank is made of high-quality noble steel. The faucet can be installed either on the left or right side. The unused faucet port is closed with a plug. **Note! The faucet and plug seals must be installed against the outer wall of the tank, not the inner wall.**

Tips to ensure proper tank function:

- Never heat up the heater when the water tank is empty.
- The water tank is intended for heating bathing water – do not put any corrosive detergents into it.
- The water used in the tank should be high-quality tap water (pay attention to saline, iron, lime and humus content)
- The water tank must be emptied and dried if it will remain unused for an extended period of time. This will prevent the build-up of slime and/or freezing.

Note! Exercise extreme caution with boiling water in the hot water tank. Boiling water and steam can seriously burn the skin!

Turning the handle on top of the heater 90° will release the water tank side from the stone tray wall. This will slow down the boiling of water in the tank. Remember to clean the water tank surfaces with stainless steel cleaner. Iron-rich water may leave rust-like spots. Clean these with a stainless steel cleaner.

Ventilation in a wood-burning sauna

Good ventilation plays a crucial role in creating truly enjoyable, comfortable sauna steam. The traditional rule for natural ventilation is to bring in fresh air just above floor level near the heater, and discharge the air as far from the heater as possible, near the ceiling. Because the heater itself is very effective at circulating air, the exhaust port is primarily used to discharge moisture after taking a sauna. Incoming air brought in near floor level runs up between the hot interior of the heater and its outer shell. The heated air rises up through the grate on top of the heater and heats the sauna room. Firewood needs a lot of air to burn – a vacuum is formed in the firebox which, together with the rising air currents, pushes the heated air out to circulate in the sauna room.

Sauna rocks

Only rocks specifically intended for use as sauna stones should be used for this purpose. Such rocks are for instance vulcanite or olivine diabase sauna stones. **NOTE!** Supracrustal stone collected from nature may contain, for example, sulphur compounds or other inappropriate substances, thus making them unsuitable for use as heater stones. The stone dust on the heater stones must be washed off before loading them into the heater. Larger stones are placed at the bottom of the stone tray so that the even surfaces face the inside surfaces of the stone tray. Smaller stones are placed on top, as they reserve heat even further away from the source of the heat. The moisture level of the sauna steam depends on the amount of stones and sauna temperature. The more stones there are in the heater and the lower the sauna temperature and the higher the moisture level.

Heating up

Wood is the only material that should be burned in the heater. Never use materials with high heat capacity, such as particle board, plastic, charcoal or briquettes. Air is circulated by opening the ash drawer. Excess draught will cause the heater to glow, which will significantly shorten its service life. Air circulation should, however, be kept at a reasonable level in order to heat up the sauna rocks to an adequate temperature. Occasionally heating up the heater with stronger draught will burn off soot accumulation in the flue ducts and improve the heater's heating properties.

The heating up the sauna room depends on the room dimensions, heater output and the materials used in the walls. Uninsulated walls (brick, tile, concrete, glass) increase the need for additional heater output: 2 m³ of additional air capacity must be calculated for every square metre of wall space. If the sauna walls are made of solid timbers, the cubic air capacity must be multiplied by 1.5.

The heater fire grate must be cleaned and ash drawer emptied before each heating.

Avoid heating up when the flue duct in the stone tray has been glowing hot for a long time, as this will overload the heater firebox and shorten the useful service life of the heater. After taking a sauna bath a small fire can be left burning to help dry out the sauna room structures.

Water quality

Clean tap water must be used for sauna steam water. Check the quality of the water. Water with a high saline, iron or humus content may cause premature corrosion of the heater. Iron-rich water may also leave rust-like spots on the surface of the heater when it dries. Clean the "rust spots" with a stainless steel cleaner. Never use sea water on the sauna heater. The warranty does not cover damages caused by sea water or iron-rich water.

Flue duct-mounted water tank

Wood-burning heaters (excluding the Ukkotonttu heater) can be fitted with a 22 litre, flue duct-mounted water tank.



Changing the direction of door opening

Firebox door

The firebox door can be installed to open from the left or right.

There are pre-installed hinge mounts on either side of the firebox door opening (see figure).

Mounting the door

Line up the door and hinge mounts. Insert the hinge pin through the first hole from above, push the pin into the guide channel and then pull down.

The bent section of the hinge pin should be at the bottom.

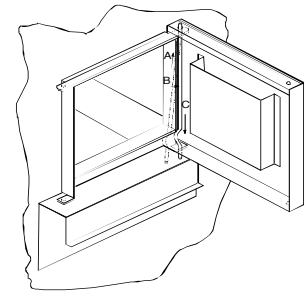
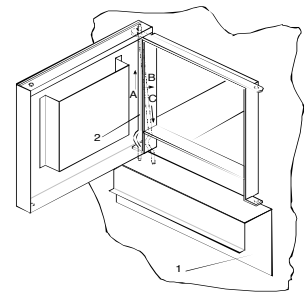

Heater care and maintenance

Kiukaan savukanaviin kertynyt noki ja tuhka on poistettava silloin tällöin kivitalan päällä (mallista riippuen) olevan pyöreän nuohousluukun kautta. Kiuaskivet rapautuvat käytön Soot and ash accumulated in the heater flue ducts must be removed on a regular basis using the round soot hatch on top of the stone tray (depending on the model). Sauna rocks will crumble over time, which is why they must be reloaded at least once a year, more often with heavy use. Stone debris accumulated in the stone tray must be removed and crumbling stones replaced.

The chimney must be swept regularly in order to maintain proper air circulation. The heater ash drawer must be emptied before each heating to allow combustion air running through it to cool the fire grate, thus extending its service life. A metal container, preferably with legs, should be reserved for collecting ash. NOTE! Because removed ash may contain hot embers, do not keep the metal container near combustible materials.

Bright or brushed steel surfaces should be wiped down regularly using, for example, a normal cleanser. This will prevent the formation of lime and reduce the amount of spots caused by iron-rich water.

Cast iron door care:

Cast iron parts should be coated regularly, for example, with cooking oil in order to prevent rusting. Cleaning glass surfaces: Take a moistened paper towel and dip it in some ash. Use this to clean the glass surface and then dry with a clean paper towel. This will brighten the glass.

Troubleshooting

1. Connecting to the chimney

- Use only Saunatec connecting flue ducts, feed-through collars, cover plates and connectors.
- Check the fire safety of the chimney connection seal (use mineral wool or ceramic fibre, if necessary).
- Do not mount the light-duty flue to the heater. Attach the light-duty flue to sauna structures only.
- Ensure that the connecting flue duct diameter is correct and the joint is tight.

2. Other fireplaces on the same chimney

- Install one fireplace per chimney. Check fireplace function.

3. First heating: burning and other smells

- The first heating should be done in the sauna without rocks with the heater connected to the chimney. The sauna must be thoroughly ventilated, and the heater must be heated for an adequate length of time (min. 3-5 loads of firewood).
- If the first heating is done outdoors, a minimum of 2-metre metal duct must be used as a flue duct.

4. Direct installation using adjustable feet

- Install the heater on an even base using Saunatec adjustable feet if necessary (accessory).

5. Sauna rocks, care and quality

- Use Saunatec-approved, prewashed rocks specifically intended for use in a sauna heater (no ceramic).
Reload and, depending on the frequency of use, replace sauna rocks at least once a year.

6. Stones that do not heat up

- Check the seal on chimney structures.
- Reduce the draught.
- The chimney will require a damper if multiple fireplaces are connected to it. The other fireplace(s) are always closed with a damper.
- Cleaning hatch is leaking.

7. Side panels and rear parts are overheating

- Check the seals on chimney and flue duct structures.
- Overheating can shorten the useful service life of the heater.

8. Ash drawer

- Empty the ash drawer regularly – before each heating.

9. Sauna steam water

- We recommend the use of clean, fresh tap water.

10. Winter storage

- If the heater will be kept in the cold for the winter, remove all heater stones and clean out the stone tray. Empty the ash drawer and water tank.

11. Fire safety instructions

Before installation, check with your local fire safety authority on the most recent fire safety regulations in force.

